

# Specifications

MODEL		TZ™-34/20	
MEASUREMENTS		US	Metric
Working height*		40 ft	12.36 m
Platform height		34 ft	10.36 m
Entry height - extended		6.4 in	.16 m
Horizontal reach		18 ft 4 in	5.59 m
Clear out reach		13 ft 5 in	4.09 m
Up and over clearance		16 ft 1 in	4.90 m
<b>A</b> Platform length		2 ft 2.8 in	.68 m
<b>B</b> Platform width		3 ft 8 in	1.12 m
<b>C</b> Height - stowed		6 ft 4.5 in	1.94 m
<b>D</b> Length - stowed		18 ft .5 in	5.50 m
<b>E</b> Width - stowed		4 ft 9.1 in	1.45 m
<b>F</b> Ground clearance		9.5 in	.24 m
<b>G</b> Length - outrigger footprint		10 ft 8.4 in	3.26 m
<b>H</b> Width - outrigger footprint		11 ft 9.4 in	3.59 m

PRODUCTIVITY			
Lift capacity (ANSI, CSA) - standard		500 lbs	227 kg
Lift capacity (ANSI, CSA) - rotating platform		460 lbs	209 kg
Lift capacity (CE/AUS) - standard		440 lbs	200 kg
Lift capacity (CE/AUS) - rotating platform		400 lbs	181 kg
Self leveling platform		standard	
Platform rotation option		90° mechanical	
AC power to platform		standard	
Turntable rotation		359° non-continuous	
Outrigger leveling capability		10.5°	
Towing speed rate		60 mph	97 km/h
Tongue weight - ANSI, CSA		315 lbs	143 kg
Tongue weight - CE		163 lbs	74 kg
Surge and parking brakes		standard	
Controls		variable speed system	
Tire size		ST 205/75 R15	
Coupler		2 in (5.08 cm) hitch coupler standard	

POWER			
Power source		24 V DC (four 6 V 225 Ah batteries)	
Hydraulic tank capacity		2.1 gal	8 L
Hydraulic system capacity		4.5 gal	17 L

WEIGHT**			
ANSI, CSA, Australia		3,155 lbs	1,431 kg
CE		3,170 lbs	1,438 kg

**STANDARDS COMPLIANCE** ANSI A92.2, CSA C225, CE Compliance, AS 1418.10, PB-10-611-03

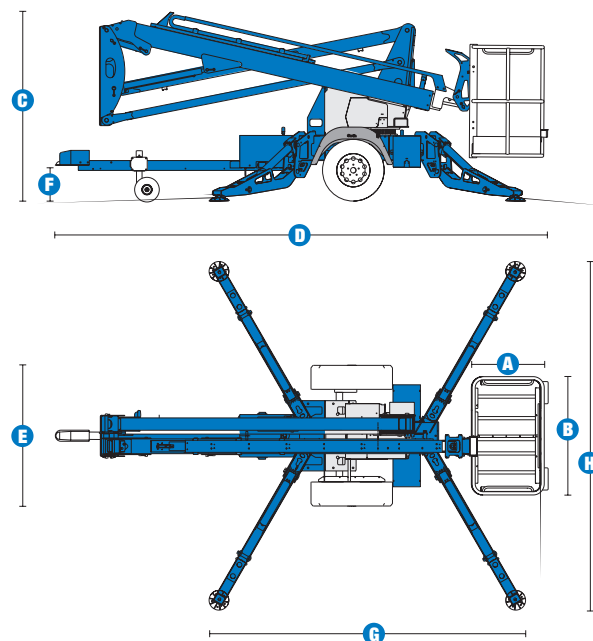

## RANGE OF MOTION TZ™-34/20

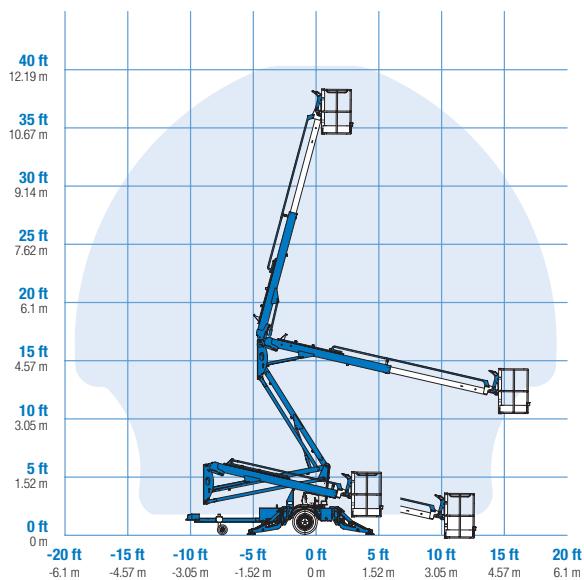

\* The metric equivalent of working height adds 2 m to platform height. U.S. adds 6 ft to platform height.  
 \*\* Weight will vary depending on options and/or country standards.

## Features

### EASILY CONFIGURED TO MEET YOUR NEEDS

#### PLATFORM OPTIONS

- Aluminum 26.8 x 44 in (.68 x 1.12 m)
- 90° mechanical platform rotation

#### POWER

- 24 V DC power source

#### COUPLER OPTIONS

- 2 in (5.08 cm) ball coupler
- 2.31 in (5.87 cm) ball coupler
- 2.5 in (6.53 cm) I.D. pintle ring coupler
- Combination hitch
- Clevis coupler

#### TIRE OPTIONS

- ST 205/75 R15 tires (ANSI, CSA)
- 185 R14C tires (CE)

### STANDARD FEATURES

#### MEASUREMENTS

- 40 ft (12.36 m) working height
- 18 ft 4 in (5.59 m) horizontal reach
- Up to 500 lb (227 kg) lift capacity

#### PRODUCTIVITY

- Industry leading working envelope
- Extension boom
- Self-leveling platform
- Variable speed control system
- AC wiring to platform
- Hydraulic outriggers
- Automatic 10.5° leveling system
- Outrigger interlocks
- Mechanical parking brake
- Hydraulic surge brakes
- Auxiliary pump down
- 2 in (5.08 cm) coupler lever lock
- Hitch pull bar
- Combination hitch with coupler lever lock
- Dual jockey wheels
- 359° non-continuous turntable rotation
- Easy to access batteries
- Hour meter
- Tilt alarm / sensor
- Forklift pockets
- Illuminated outrigger indicators

#### POWER

- 24V DC power source  
(four 6V 225 Ah batteries)



### OPTIONS & ACCESSORIES

#### PRODUCTIVITY

- 90° mechanical platform rotation
- 2 in (5.08 cm) ball coupler
- 2.31 in (5.87 cm) ball coupler
- 2.5 in (6.53 cm) I.D. pintle ring coupler
- Combination hitch
- Clevis coupler
- Wheel chocks
- Fluorescent tube caddy
- Full size spare tire
- Operational warning beacon package
- Non-marking outrigger footpads
- Battery charge indicator (BCI)
- Tool tray

### Genie United States

18340 NE 76th Street  
P.O. Box 97030  
Redmond, Washington 98073-9730

Telephone **(425) 881-1800**  
Toll Free in USA/Canada **800-536-1800**  
Fax (425) 883-3475

### Genie Europe

The Maltings  
Wharf Road  
Grantham NG31 6BH  
U.K.

Telephone **+44 (0)1476 584333**  
Fax +44 (0)1476 584334

Email: [infoeurope@genieind.com](mailto:infoeurope@genieind.com)

### Distributed By:



**Kevin Keeter • 817.271.0405**

For further information, please contact your local distributor or the Genie Industries sales office listed. Product specifications are subject to change without notice or obligation. The photographs and drawings in this brochure are for illustrative purposes only. Refer to the appropriate Operator's Manual for instructions on the proper use of this equipment. Failure to follow the appropriate Operator's Manual when using our equipment or to otherwise act irresponsibly may result in serious injury or death. Prices and specifications subject to change without notice. The only warranty applicable is the standard written warranty applicable to the particular product and sale. Genie makes no other warranty, expressed or implied. Products and services listed may be trademarks, service marks or trade-names of TEREX Corporation and/or its subsidiaries in the USA and other countries and all rights are reserved. Copyright © 2006 Genie Industries, Inc. "Genie" is a Registered Trademark of Genie Industries, Inc. in the USA and many other countries. Genie is a TEREX Company.